



Elix

The Refrigeration air dryers

- > World-class 3 in 1 PHE for optimum performance
- > Electronic Load Tracking ensures consistency in dT
- > Microchannel condenser offers potential savings in Energy
- > PLC based control & protection

NEW | DIMENSIONS SOLUTIONS



ElixPlus Exclusive Features



1. Step cooling to uplift the part load efficiency

Modular Cooler configuration & Integrated control

Flow characteristics play a vital role in improving efficiency of heat transfer. At part load, the flow characteristics change drastically reducing the efficiency of heat exchanger.

Elixplus Modular Cooler configuration & Integrated control make use of the **Step cooling technology** which effectively control the flow inside the cooler and **keep the efficiency at higher level even at part load condition.**

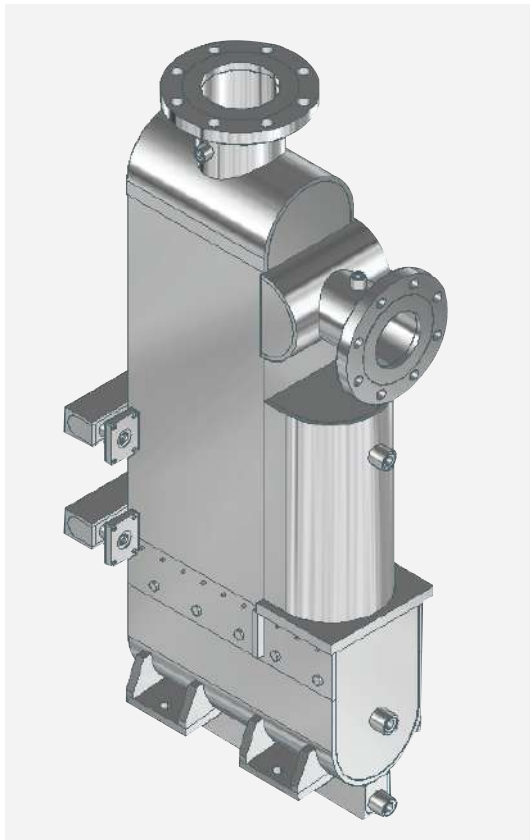

2. Elix Heat exchanger with high-performance surface:

The uniqueness of Summits Elix dryers lies in the internal construction of its heat exchanger. Selectively chosen fin type & optimally sized geometry breaks boundary layer and creates effective turbulence with lesser pressure drop.

1°C increase in Evaporating temperature can result in 4% more cooling capacity whereas power consumption increases only by 0.5%.

Compared with conventional dryer Elix heat exchanger offer following additional benefits

- > Integrally fused fin eliminates Contact Resistance between plates and fins leading to attaining the highest heat transfer co-efficient.
- > Offset fins, besides creating better turbulence for heat exchange, also act as an efficient preliminary moisture separator.
- > Inbuilt wire mesh demister provides countless impingement surfaces to coalesce the moisture particle and hence separates it effectively.



3. PLC based control and protection Open platform & fully customizable

Elixplus dryer comes with an advanced open platform PLC with numerous features including total system monitoring, preventive maintenance alerts and compatible to industries required communication protocol such as RS485 modbus, BMS, IOT, Ethernet and Industry 4.0. Being an open platform software, the PLC can be programmed to meet your specific requirements.



4. Electronic Load tracking & Control

Instantaneous response to abrupt change in load

Elixplus Refrigeration air dryer keeps the Pressure dewpoint nearly constant even in wide operating range with quantum jump load variation with the help of electronically controlled capacity regulating valve (in selected Model).

Suction and discharge pressure transmitters ensure precise monitoring and control of process parameters.



5. Excellence of Microchannel condenser:

Conventional Tube fin condenser

- > **More resistance to fan air flow:** Staggered arrangement of tubes in conventional copper tube condenser causes increased pressure drop across the condenser which necessitates selection of higher rating fan and leads to increased power consumption.
- > **Less effective heat transfer area:** Flow separation & formation of eddy flow at the wake region around the tube is unavoidable. This eddy flow reduces effective area of heat transfer.

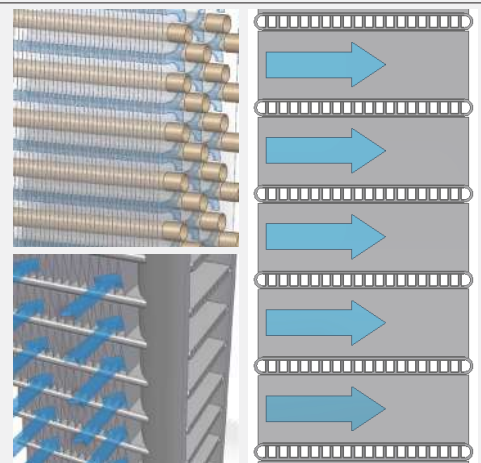
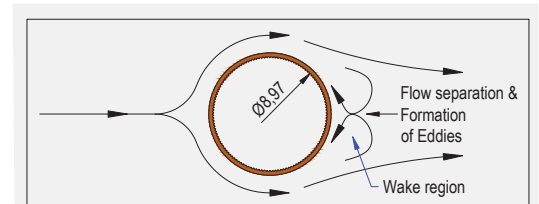

Microchannel condenser:

- > **Less resistance for air flow:** Parallel arrangement of tubes offers less resistance to fan air flow which leads to selection of lesser rating fan and reduced power consumption.
- > **More effective heat transfer area:** Flat tube construction avoids the wake region and increases effective heat transfer area. reduced power consumption.

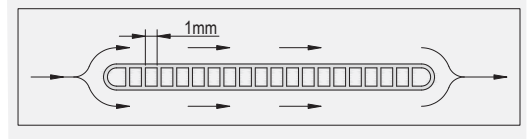

6. Pactoplus, The Smart drain valve adds bonus savings

1. Silent
2. Zero air loss
3. Ample savings



Technical Data

SI NO	Model	FAD		Overall dimension, mm			Weight	Power Supply v/ph 50 Hz	In/Out
		cfm	m ³ /h	W	D	H	Kg		
01	Elix 001 DA	10	17	400	462	459	31	230/1	G1/2"
02	Elix 002 DA	20	34	400	462	459	32	230/1	G1/2"
03	Elix 004 DA	40	68	420.5	522	459	36	230/1	G3/4"
04	Elix 006 DA	60	102	420.5	522	459	37	230/1	G3/4"
05	Elix 008 DA	80	136	470.4	632	560	54	230/1	G1"
06	Elix 010 DA	100	170	470.4	632	560	55	230/1	G1"
07	Elix 012 DA	125	212	470.4	632	560	56	230/1	G1"
08	Elix 015 DA	150	255	515	815	815	79	230/1	G1-1/2"
09	Elix 020 DA	200	340	515	815	815	90	230/1	G1-1/2"
10	Elix 025 DA	250	425	515	815	815	95	230/1	G1-1/2"
11	Elix 030 DA	300	510	586.5	815	970	138	230/1	G2"
12	Elix 040 DA	400	680	950	600	1045	142	230/1	G2-1/2"
13	Elix 050 DA	500	850	950	600	1045	144	415/3	G2-1/2"
14	Elix 060 DA	600	1020	950	600	1045	148	415/3	G2-1/2"
15	Elix 080 DA	800	1360	720	970	1425	475	415/3	DN100
16	Elix 100 DA	1000	1700	820	1095	1615	520	415/3	DN100
17	Elix 125 DA	1250	2125	820	1095	1615	530	415/3	DN100
18	Elixplus 160 DA	1600	2720	970	1420	1620	600	415/3	DN100
19	Elixplus 200 DA	2000	3400	1470	1420	2000	970	415/3	DN150
20	Elixplus 250 DA	2500	4250	1470	1420	2000	980	415/3	DN150
21	Elixplus 300 DA	3000	5100	1620	1570	2000	1150	415/3	DN150
22	Elixplus 400 DA	4000	6800	2120	1570	2000	1300	415/3	DN200
23	Elixplus 500 DW	5000	8500	1550	1650	2000	1450	415/3	DN200
24	Elixplus 600 DW	6000	10200	1700	2000	2050	2100	415/3	DN200
25	Elixplus 700 DW	7000	11900	1700	2200	2050	2450	415/3	DN250
26	Elixplus 800 DW	8000	13600	1700	2450	2100	2650	415/3	DN250
27	Elixplus 900 DW	9000	15300	1850	2450	2200	2950	415/3	DN250
28	Elixplus 999 DW	10000	17000	1850	2510	2400	3200	415/3	DN300

Note:

> Kindly contact us for capacity more than 10,000cfm.

> Water cooled option is available from **500 cfm** onwards.

> **FAD** (Free Air Delivery) is based on ISO 7183-2007

> **In/Out Flange (DN)** conforms to ASME B16.5 CL 150 LBS SORF.

Nomenclature:

> Elix 010 DA | > Elix: Series name | > 010 x 10 = 100 cfm | > D: 16 bar g | > A: Air cooled

Schematic diagram:

1. Refrigerant compressor
2. Condenser
3. Condenser cooling fan
4. Liquid receiver
5. High pressure switch
6. Fan pressure switch
7. Filter dryer
8. Liquid line sight glass
9. Solenoid valve
10. Capillary
11. Dew point sensor
12. Zero air loss drain valve
13. Moisture separator
14. Refrigerant to air heat exchanger
15. Air to air heat exchanger
16. Hot gas bypass valve
17. Accumulator
18. Pressure transmitter
19. Elixplus Controller

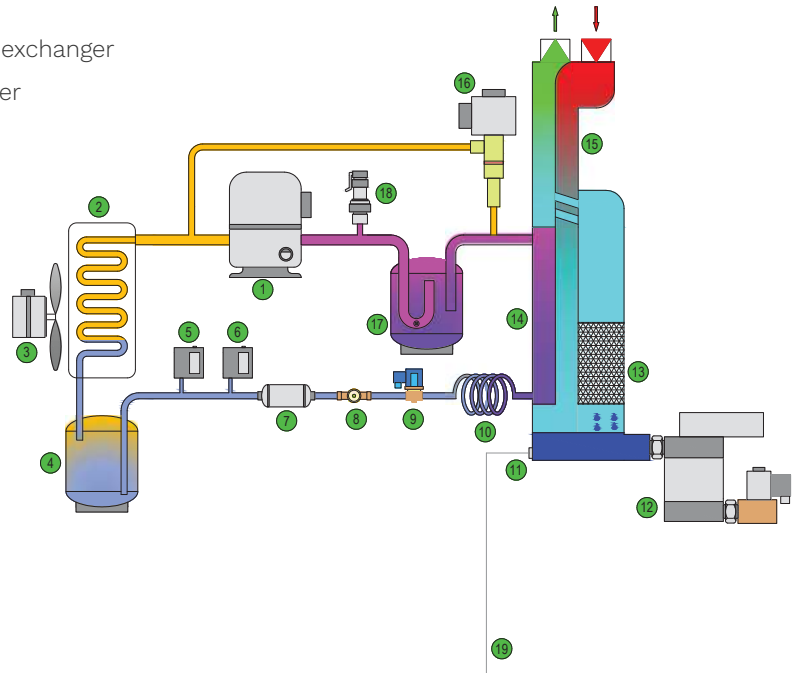

Selection example	
Compressor FAD, cfm	1175
Inlet Air Pressure, bar g	9
Inlet Air Temperature, °C	50
Ambient Temperature, °C	45
Correction factor for Inlet Air pressure, Z1	1.07
Inlet Air temp. 50°C, Z2	0.76
Ambient temp. 45°C, Z3	0.93
Multiplication of CF	1.07x0.76x0.93=0.756
Corrected FAD, cfm	1175/0.756=1554.2
Model to be chosen	Elixplus 160 DA

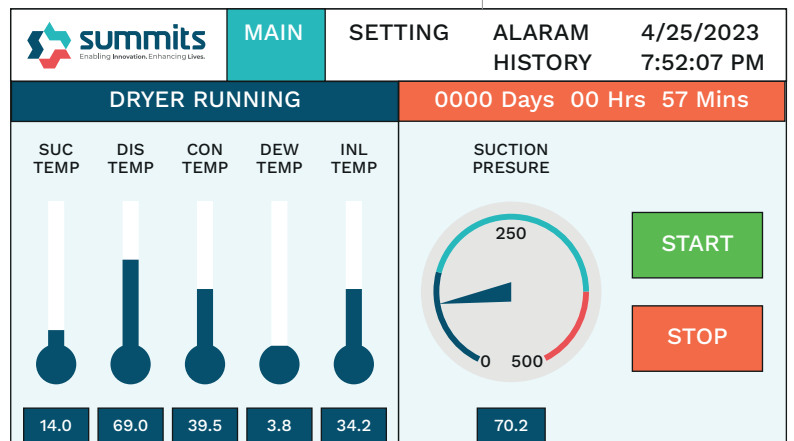

Correction factor and Selection											
Inlet Air Pressure, Z1											
Inlet Air Pressure, bar g	3	4	5	6	7	8	9	10	12	14	16
Correction Factor, Z1	0.54	0.66	0.76	0.87	1	1.02	1.07	1.1	1.17	1.24	1.31
Inlet Air Temperature, Z2				Ambient Temperature, Z3							
Inlet Air Temperature, °C	45	50	55	60	Ambient Temperature, °C	40	45	50			
Correction Factor, Z2	1.00	0.76	0.6	0.49	Correction Factor, Z3	1.00	0.93	0.85			
Boundary Conditions											
Operating Parameters	Ideal	Minimum	Maximum								
Inlet Air Temperature, °C	45	10	60								
Ambient Temperature, °C	40	1	50								
Inlet Air Pressure, bar g	7	2	16								
$\text{Dryer nominal capacity} = \frac{\text{Compressor actual FAD}}{Z1 \times Z2 \times Z3}$											

Elix VFD

Power for Productive time

Fluctuation in demand is inevitable in today's dynamic market. Industries are constantly evolving and adapting its production to this growing demand. Playing a prominent role in the production, Compressed air system needs to adapt itself to this fluctuating demand in an energy efficient way to pitch ourself on the top of the competitive edge. With VFD drive and meticulously developed integrated control logic, Elix VFD can cut down your energy cost up to 50%.



Elix VFD Control Scheme

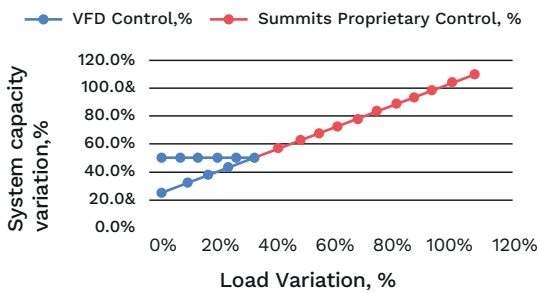

Elix VFD - Refrigerant compressor with Intelligent variable frequency drive and integrated control logic helps the system to perform efficiently with 'Exact Power at Exact consumption even during 10 to 100% load variation.

Pontential Saving (INR) per year with 1000cfm Elix VFD dryer under varying load condition

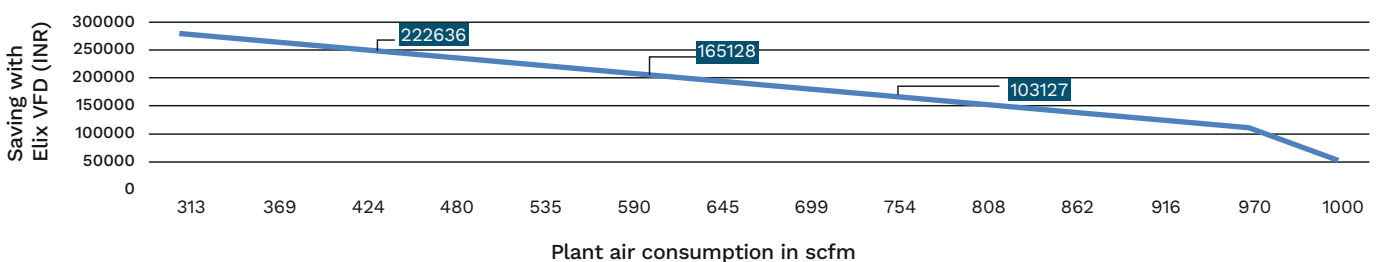



Elix Eco

With the trends towards phasing out of refrigerant with GWP (Global warming potential) of more than 700, it is wise to choose Future-ready refrigerant R513A to keep your plant ready for future statutory requirement. R407C has GWP of 1800. It means that R407C can warm this globe 1800 times more severe than CO2. Understanding the gravity of this fact, Summits has already introduced Elix Eco - compressed air dryer with low GWP refrigerant R513A.



Low GWP R513A Refrigerant



Zero air loss Pacto valve, Saves Energy and reduces Carbon footprint.



Make your plant ready to meet future statutory requirement with R513A refrigerant.

R513A is non-flammable, with an ASHRAE A1 safety classification, and offers additional benefits of Low GWP: 60% reduction of GWP compared to R-134a. No stratospheric ozone impacts. With Elix Eco, your plant can pass all environmental regulation for several years to come.

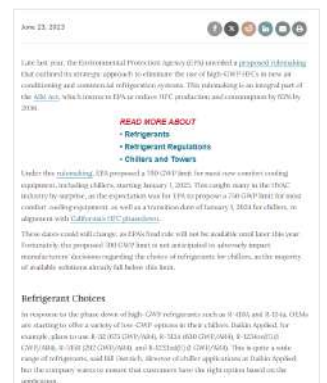
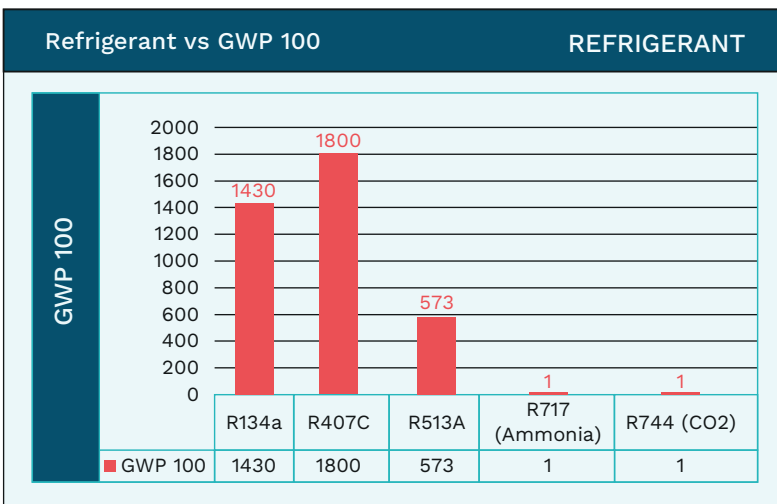

Elix HP – High pressure refrigeration air dryer



Elix HP

Elix HP dryers are tailored to excel in industries with stringent demands. The Unique 3 in 1 Aluminium heat exchangers for operating pressure up to 45 bar g and an advanced Shell and Tube heat Exchangers up to 200 bar g offer optimum performance with the lowest possible pressure drop across the system.

Elix HP dryers stand ready to meet critical high-pressure applications such as PET Bottling, Leak testing, air amplification, and other high pressure application.

Selection example

Compressor FAD, cfm	200
Inlet Air Pressure, bar g	45
Inlet Air Temperature, °C	50
Ambient Temperature, °C	45
Correction factor for	
Inlet Air pressure, 45 bar g, Z1	1.15
Inlet Air temp. 50°C, Z2	0.85
Ambient temp. 45°C, Z3	0.93
Multiplication of CF	1.15X0.85X 0.93=0.909
Corrected FAD, cfm	200/0.909= 220.02
Model to be chosen	Elix 025 EA

Elix HP Heat exchanger

Add on Features:

1. Discharge temperature sensor
2. Micro-channel condenser
3. Zero air loss drain valve on demand

Note:

Kindly contact us for capacity more than 600cfm. Water cooled option is available. FAD (Free Air Delivery) is based on ISO 7183-2007.

Nomenclature:

Elix 010 EA E: 45 bar g
Elix: Series name A: Air cooled
010 x 10 = 100 cfm

SI NO	Model	FAD		Overall dimension, mm			Weight Kg	Power Supply v/ph 50 Hz	In/Out
		cfm	m ³ /h	W	D	H			
01	Elix 001 DA	10	17	400	462	459	32	230/1	G1/2
02	Elix 002 DA	20	34	400	462	459	33	230/1	G1/2
03	Elix 004 DA	40	68	420.5	522	459	37	230/1	G3/4
04	Elix 006 DA	60	102	420.5	522	459	38	230/1	G3/4
05	Elix 008 DA	80	136	470.4	632	560	55	230/1	G1
06	Elix 010 DA	100	170	470.4	632	560	56	230/1	G1
07	Elix 012 DA	125	212	470.4	632	560	57	230/1	G1
08	Elix 015 DA	150	255	515	815	815	80	230/1	G1-1/2
09	Elix 020 DA	200	340	515	815	815	92	230/1	G1-1/2
10	Elix 025 DA	250	425	515	815	815	97	230/1	G1-1/2
11	Elix 030 DA	300	510	950	600	1045	140	230/1	G2
12	Elix 040 DA	400	680	950	600	1045	145	230/1	G2
13	Elix 050 DA	500	850	950	600	1045	148	415/3	G2
14	Elix 060 DA	600	1020	950	600	1045	148	415/3	G2

Schematic diagram of Elix HP

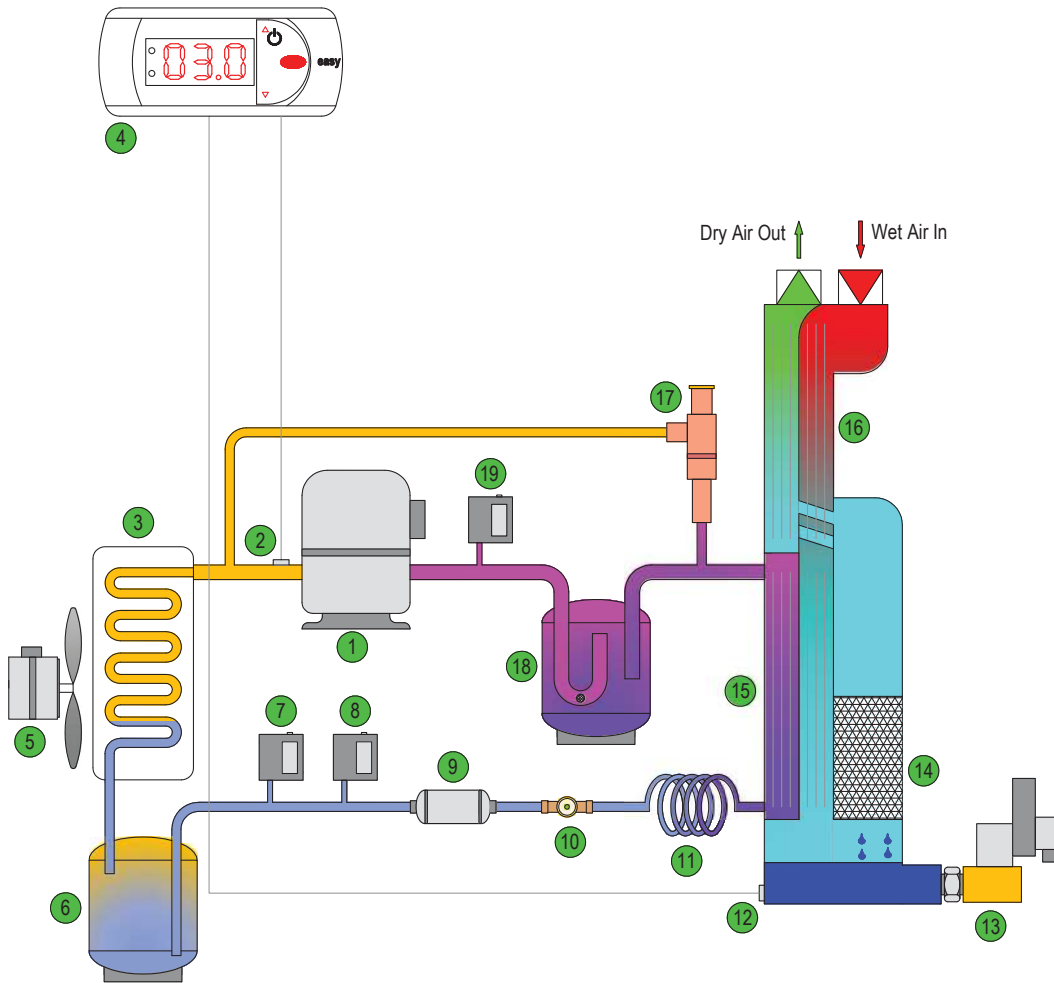

Selection example

1. Refrigerant compressor
2. Discharge temp. sensor
3. Condenser
4. Controller
5. Condenser cooling fan
6. Liquid receiver*
7. High pressure switch*
8. Fan pressure switch
9. Filter dryer
10. Liquid line sight glass*
11. Capillary
12. Dew point sensor
13. Auto drain valve
14. Moisture separator
15. Refrigerant to air heat exchanger
16. Air to air heat exchanger
17. Hot gas bypass valve
18. Accumulator*
19. Low pressure switch*

* Only in selected model

Correction factor and Selection

Inlet Air Pressure, Z1

Inlet Air Pressure, bar g	15	20	25	30	35	40	45
Correction Factor, Z1	0.68	0.80	0.90	1.00	1.05	1.10	1.15

Inlet Air Temperature, Z2

Inlet Air Temperature, °C	45	50	55	60
Correction Factor, Z2	1.00	0.85	0.74	0.63

Ambient Temperature, Z3

Ambient Temperature, °C	40	45	50
Correction Factor, Z3	1.00	0.93	0.85

Boundary Conditions

Operating Parameters	Ideal	Minimum	Maximum
Inlet Air Temperature, °C	45	10	60
Ambient Temperature, °C	40	1	50
Inlet Air Pressure, bar g	30	15	45

$$\text{Dryer nominal capacity} = \frac{\text{Compressor actual FAD}}{Z1 \times Z2 \times Z3}$$

Harvesting the elements of air through innovation for

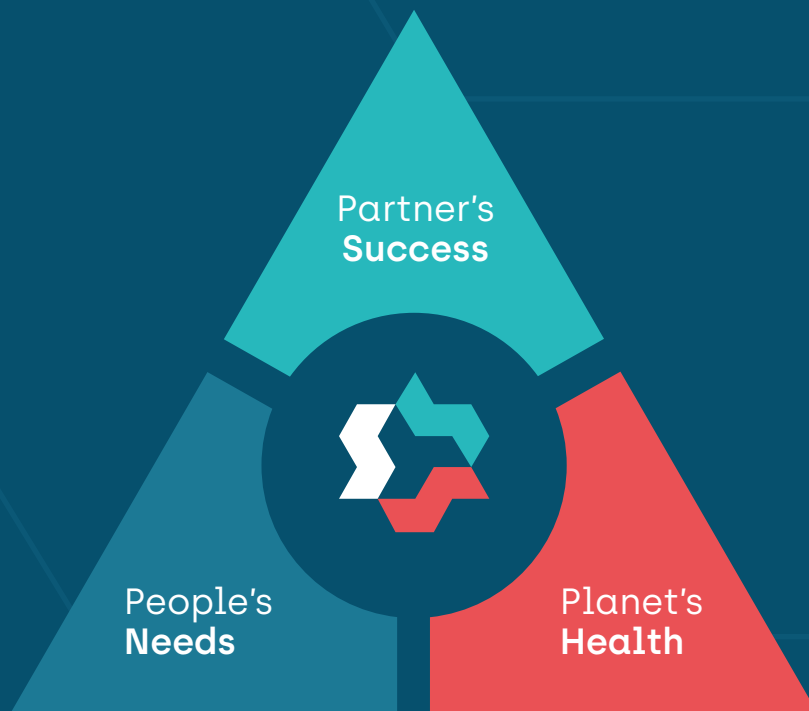

Manufactured and marketed by

 **Summits Hygronics Private Limited**

SF.192 Earithottam, Kannampalayam,
Coimbatore - 641402. Tamilnadu, India.

P: +91 95009 96000

 enq@summitsgroup.in  www.airdryer.in

**Nearest Channel Partner /
Business Associate**